

PILLAR Slide Bearing Series

Seismically Isolated Slide Bearing

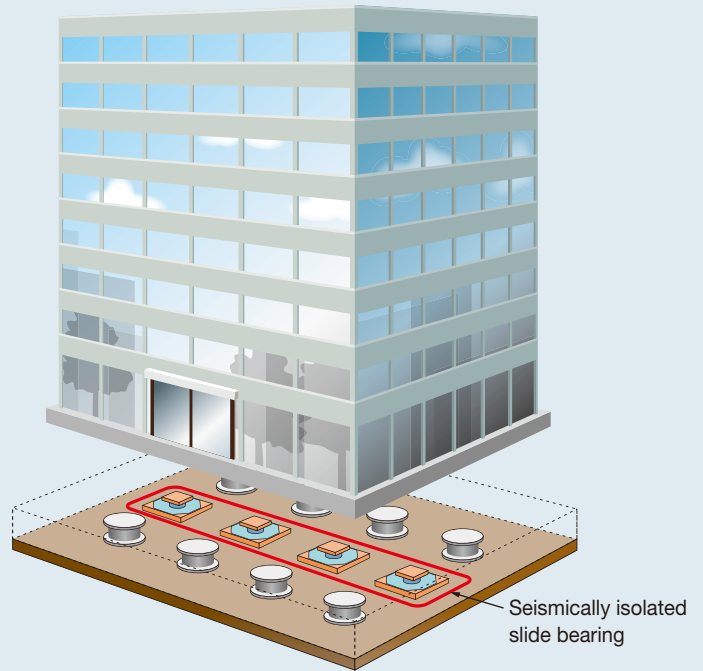

Slide bearing for base-isolated buildings that applies low friction characteristics of fluorocarbon polymers



Installing this product under relatively lightweight structures such as auxiliary facilities (elevators, stairs, peripheral lower sections, etc.) of base-isolated buildings can make seismic isolation systems more effective.

Features

- This product can be applied to a wide range of base-isolated buildings including low-rise buildings, high-rise buildings, factory facilities, and apartment houses.
- This product employs a simple structure, making maintenance easy.
- This product allows for tracking of large deformations and response to longer natural period of buildings.
- The elastomer sealed inside the base pot rotates vertically to allow for tilt and absorb an installation error of 1/500 ($\pm 0.11^\circ$).

Installation example

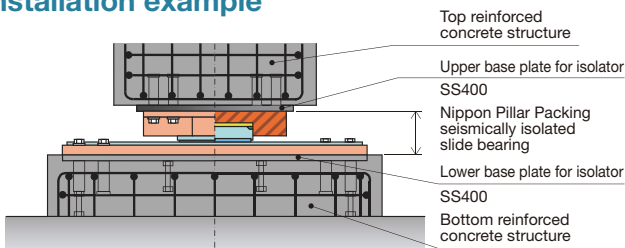

Structure

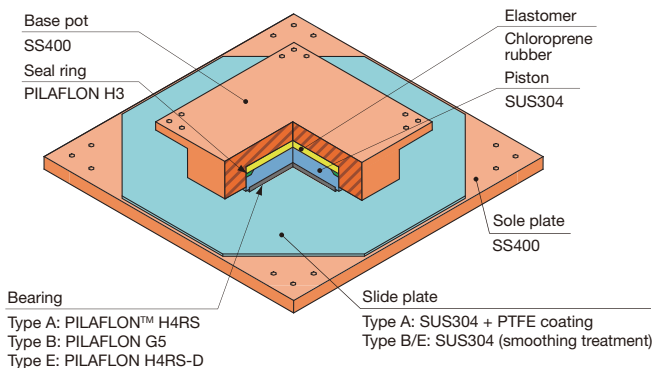

* PILAFLO is our trademark of molded products made of polytetrafluoroethylene (PTFE, PTFE containing filler).

Product lineup

This product is classified into the following three types according to the coefficient of friction on sliding surfaces: Type A ($\mu = 0.011$), Type B ($\mu = 0.095$), and Type E ($\mu = 0.0080$).

Type A

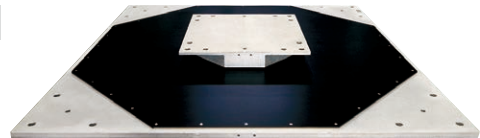

Type B Type E

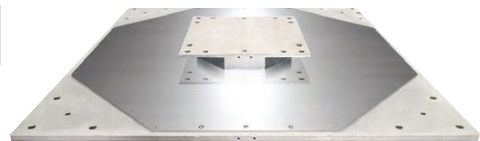

Minister certification

This product has been subjected to performance evaluation based on the regulations on Item 2 (seismic isolation materials) of Article 37 of the Building Standards Act and certified by the Minister of Land, Infrastructure, Transport and Tourism.



Certification number: MVBR-0606



Certification number: MVBR-0607



Certification number: MVBR-0623

Seismically Isolated Slide Bearing

Standard specifications

Item		Certification number: MVBR-0606 Type A $\mu=0.011$	Certification number: MVBR-0607 Type B $\mu=0.095$	Certification number: MVBR-0623 Type E $\mu=0.0080$
Standard materials	Metal materials*1	SS400 (JIS G 3101), SUS304 (JIS G 4303/4304/4305)		
	Bearing	PILAFLON H4RS	PILAFLON G5	PILAFLON H4RS-D
	Slide plate*1	SUS304+PTFE coating	SUS304 subjected to smoothing treatment	SUS304 subjected to smoothing treatment
	Rubber	Chloroprene rubber (JIS K 6386-C08)		
	Painting*2	Undercoat: Zinc-rich paint Intermediate coat: Epoxy resin paint Topcoat: Epoxy resin paint (Munsell N6.0 light gray)		
Standard design conditions	Long-term vertical load kN	100 to 10000		
	Short-term vertical load kN	200 to 20000 (Long-term vertical load \times 2.0)		
	Standard coefficient of friction*3	0.011	0.095	0.0080
	Variations in coefficient of friction %	± 30	± 20	± 40
	Standard surface pressure N/mm ²	20		
	Displacement magnitude mm	$\pm 300, 350, 400, 450, 500, 550, 600, 650, 700, 750, 800, 850, 900$		

*1 Base pots and sole plates can also be made of rolled steel for welded structures. Similarly, slide plates can also be made of SUS316 stainless steel.

*2 Galvanization can also be applied instead of painting.

*3 These values are applicable when the surface pressure is 20 N/mm², the maximum speed of a sine wave is 400 mm/s, and the third cycle is in operation.

Performance

Velocity dependence

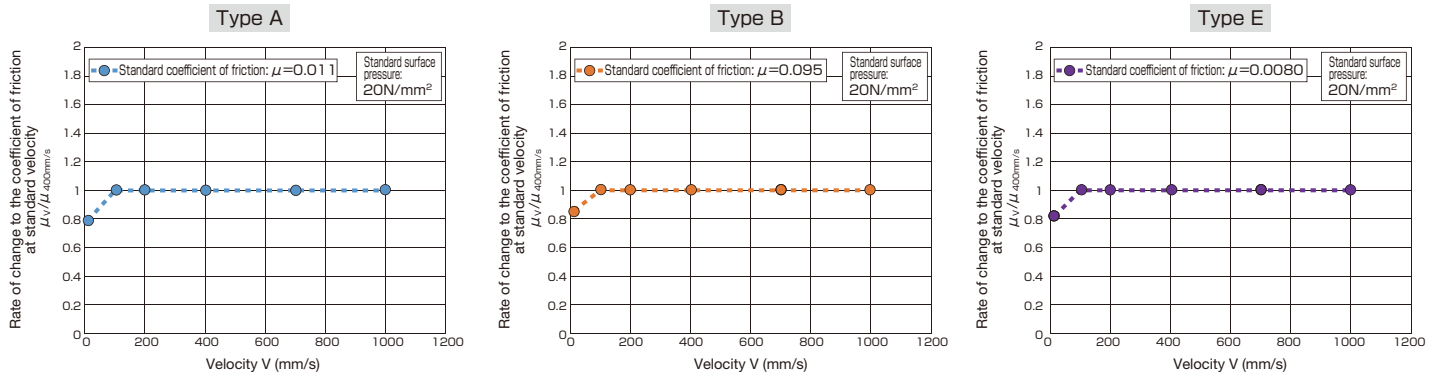

Surface pressure dependence

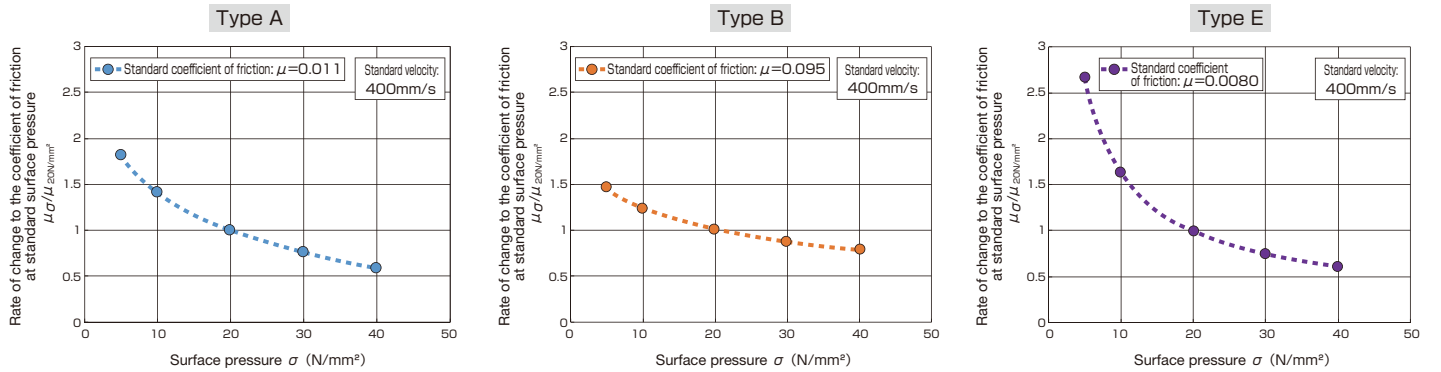

Hysteresis loop

* These loops are applicable at the standard surface pressure and standard velocity and in the third cycle.

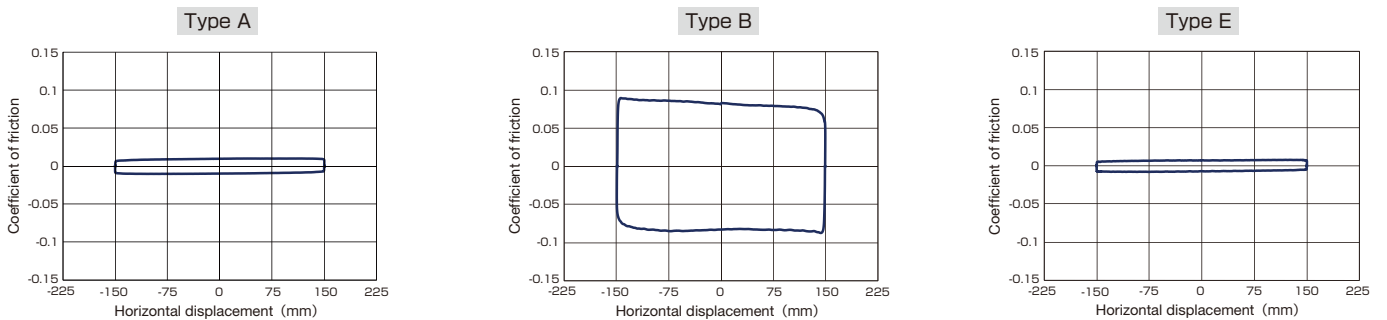

Seismically Isolated Slide Bearing

Example of installation procedure

1. Style of packing for bearing

- 1.1 The bearing body has its upper and lower shoes secured with temporary securing brackets and is equipped with lifting eyebolts.
- 1.2 The slide plate of the bearing has protective materials (plywood with sponge sheets) mounted.

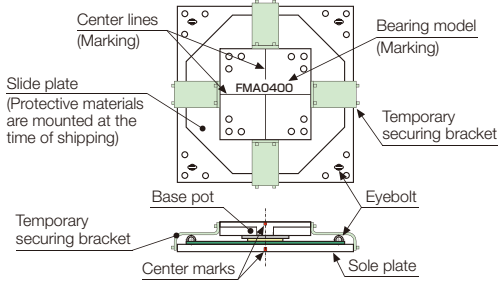

2. Installing the lower base plate for isolator (Reference)

- 2.1 Mark the center of the bearing on the concrete.
- 2.2 Install the lower base plate for isolator so that it aligns with the center of the bearing.
- 2.3 Arrange reinforcing bars in the bottom structure so that they surround the anchor rebar on the bottom surface of the lower base plate for isolator.
- 2.4 Remove the eyebolts.
- 2.5 After confirming horizontal alignment between the base plate for isolator and the reference line, use the level adjustment bolts in the four corners to adjust levelness, flatness, and standard height.

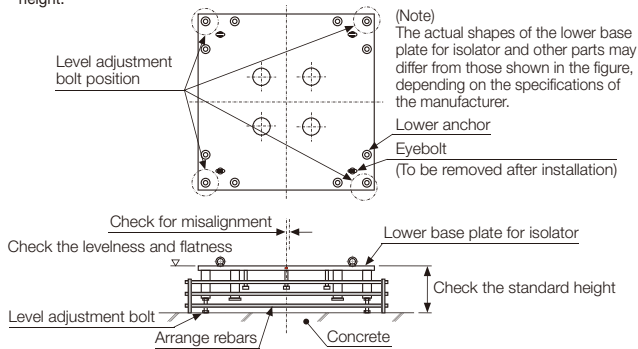

3. Casting raised concrete (Reference)

- 3.1 Firmly secure the lower anchor or lower anchor rebar and the arranged reinforcing bars by spot welding or with annealed wires (binding wires).
- 3.2 Install a formwork for raised concrete.
- 3.3 Cast concrete into a grout hole on the lower base plate for isolator or into a gap between the formwork and the lower base plate for isolator.

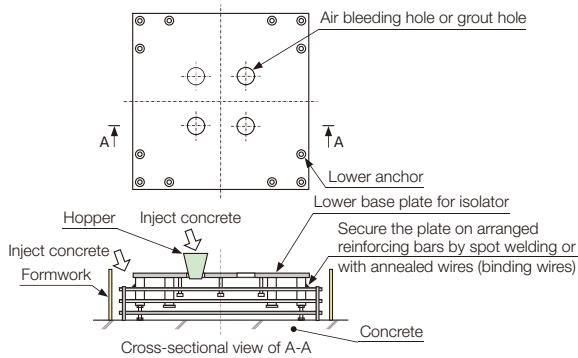

- 3.4 Check the levelness and flatness of the top surface of the lower base plate for isolator.

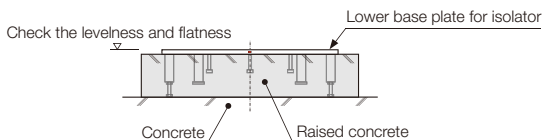

4. Installing the bearing body

- 4.1 Clean the installation surfaces (the top surface of the lower base plate for isolator and the bottom of the bearing body).
- 4.2 Install the bearing body and secure it with mounting bolts.
- 4.3 Check the tightening status of each mounting bolt and leave a mark indicating that the tightening status has been checked.
- 4.4 Remove the eyebolts from the bearing body and insert a screw plug into the screw hole for each eyebolt.

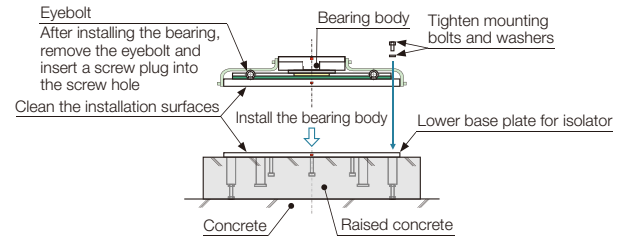

5. Installing the upper base plate for isolator

- 5.1 Clean the installation surfaces (the top surface of the bearing body and the bottom of the upper base plate for isolator).
- 5.2 Install the upper base plate for isolator and secure it with mounting bolts.
- 5.3 Check the tightening status of each mounting bolt and leave a mark indicating that the tightening status has been checked.

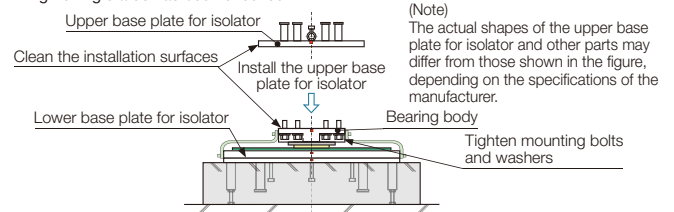

6. Installing the top structure

- 6.1 Check the fitting status of the upper anchor and upper anchor rebar first and then arrange the upper reinforcing bars in the top structure.
- 6.2 Assemble a formwork around the upper base plate for isolator.
- 6.3 Cast concrete.
- 6.4 After the specified concrete curing period elapses, remove the formwork.

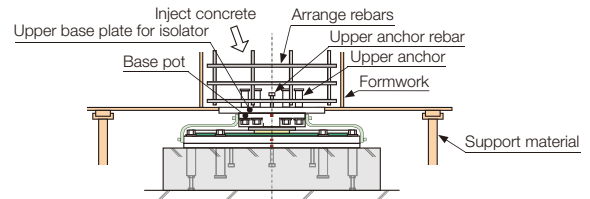

7. Finishing installation

- 7.1 Because of the building construction work process, make a plan to remove the temporary securing brackets when the bearing is ready to work and there are no problems.
- 7.2 Remove the temporary securing bracket and insert screw plugs (accessories) into the screw holes from which the temporary securing bracket was removed.

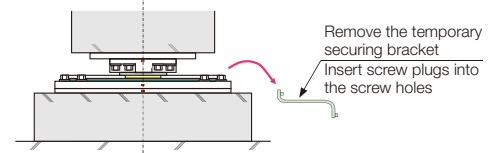

- 7.3 Remove the protective materials from the slide plate and install a dust cover (optional).

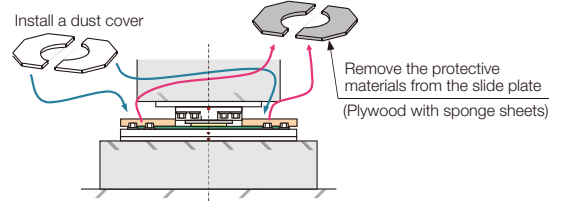

PILLAR NIPPON PILLAR PACKING CO., LTD.

Head office/Sales Headquarters
7-1, Shinmachi 1-chome, Nishi-ku, Osaka 550-0013, Japan
Phone: +81-6-7166-8326 Fax: +81-6-7166-8514

Email : sales@pillar.co.jp

<https://www3.pillar.co.jp/en/product/>



Safety precaution

- When using this product, please use correctly and pay sufficient attention to safety.

* Please understand that this catalog may change without prior notice.
* The values shown on this catalog are reference values, not guaranteed values.

PPLC2227-1/CAT.No.233004