

Automatically reducing bellows pump pulsation

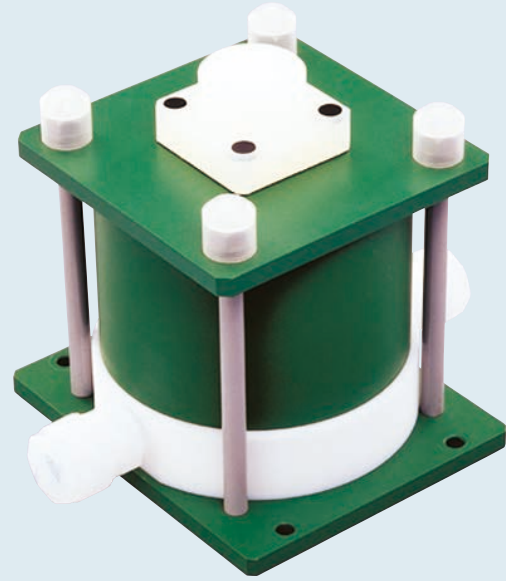

■ Features

Automatic pressure control

The accumulator allows air pressure to automatically follow bellows pump pressure fluctuations, reducing the pulse pressure.

Smooth draining

The opening in the bellows faces downward, which allows the fluid to flow well, enabling quick draining when the pump is stopped.

■ Example of use

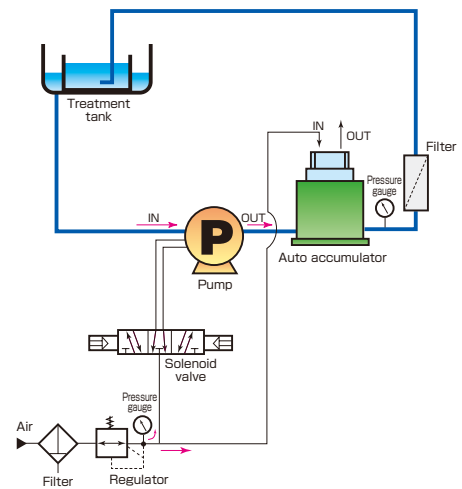

■ Specifications

Model		PA-10HB	PA-20HB	PA-40HB	PA-80HB	PA-100H
Applicable pumps		PE-5MA PE-10MA PE-10HB	PE-20MA PE-20HB	PE-40MA PE-40HBH	PE-80MA	PK-100H
Liquid connection diameter		φ12×φ10	φ19×φ15.8	φ25×φ22		φ31.8×φ28
Liquid connector		Super 300 Type Pillar Fitting™				
Operating temperature range	℃	10 to 180			10 to 80	10 to 180
Operating pressure range*	MPaG	0 to 0.45				0 to 0.65
Supply air pressure*	MPaG	0.2 to 0.5				0.2 to 0.7
Pulsation pressure range		Within ±12.5% of the pump discharge pressure when it is 0.16 MPaG or more (0.2 MPaG or more for PA-100H) 0.04 MPaG or lower when the pump discharge pressure is less than 0.16 MPaG (less than 0.2 MPaG for PA-100H)				
Air inlet ports		Rc 1/4				
Weight	kg	Approx. 3.5	Approx. 8	Approx. 9.5	Approx. 13.5	Approx. 22

* The operating pressure range and supply air pressure differ according to the applicable pump or operating temperature. Before using the product, please check the relevant sections in the operation manual.

Structural drawings and size table

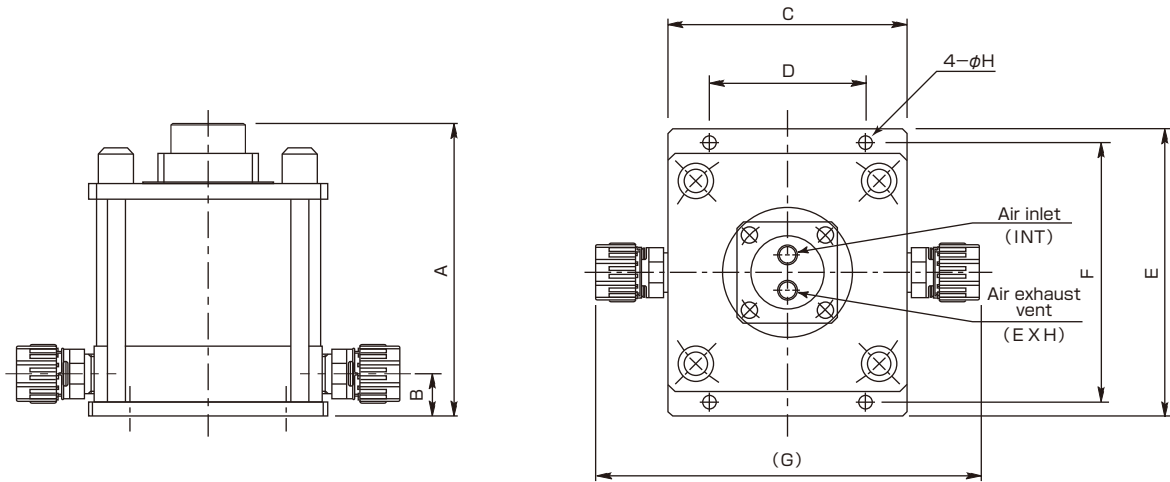

Unit: mm

Model	A	B	C	D	E	F	(G)	φH
PA-10HB	176	23	133	86	164	145	210	9
PA-20HB	199	29	162	106	195	176	260	9
PA-40HB	286	32.5	188	122	225	204	309	11
PA-80MB	298	34.5	228	150	265	244	348	11
PA-100H	328.5	49.5	228	150	265	244	402	11

Read the operation manual before use.

PILLAR NIPPON PILLAR PACKING CO., LTD.

Head office/Sales Headquarters
7-1, Shinmachi 1-chome, Nishi-ku, Osaka 550-0013, Japan
Phone: +81-6-7166-8326 Fax: +81-6-7166-8514

Email : sales@pillar.co.jp

<https://www3.pillar.co.jp/en/product/>



Safety precaution

● When using this product, please use correctly and pay sufficient attention to safety.

* Please understand that this catalog may change without prior notice.
* The values shown on this catalog are reference values, not guaranteed values.